

| Chapter amendments approved:                     | OMPC      | Owensboro                                | Daviess Co. | Whitesville |
|--|-----------|--|-------------|-------------|
| Re-adoption of Public Improvement Specifications | 24-Mar-77 | 01-Apr-77                                | 20-Apr-77   | ?           |
| Revised Public Improvement Specifications        | 18-Apr-81 | 22-May-81                                | 26-May-81   | 06-Jul-81   |
| 2002 Revised Public Improvement Specifications   | 08-Aug-02 | No action required by legislative bodies |             |             |

**4.0 PURPOSE.** The purpose of this Chapter is to outline requirements for proper design, construction, and inspection of concrete sidewalks, curb, and gutter.

**4.1 SIDEWALKS, CURB, AND GUTTER.** Sidewalks, curb, and gutter shall be in accordance with the following specifications and subject to approval by the Engineer.

**4.2 CONCRETE SIDEWALKS.** Sidewalks shall be constructed of Portland Cement Concrete in accordance with the requirements shown on the Plans and the provisions of this specification.

**4.2.1 Materials.** The concrete shall be Class "A", it shall have a minimum 28-day compressive strength of 3500 psi, and shall have a minimum slump of two (2) inches and a maximum slump of four (4) inches. For fiber reinforced concrete, a slump tolerance of plus one inch shall be allowed outside of the maximum. Air entrainment shall be required with content by volume of 5.5 plus or minus 1.5 percent. Where fiber mesh is used, the curing process may not be required.

Expansion joint material shall conform to the requirements of KTC Specifications.

**4.2.2 Construction Methods.** The sidewalk and sidewalk aprons shall be constructed on a prepared, compacted smooth subgrade of uniform density formed by trenching or filling to the required elevation. Large boulders and ledge rock found in the subgrade shall be removed to a minimum depth of six (6) inches below the finished subgrade elevation and the space shall be backfilled with suitable material, which shall then be thoroughly compacted by rolling or tamping.

The forms shall be of either metal or wood and shall be straight, free from warp, of sufficient strength to resist springing during construction, and of a height approximately equal to the depth of the sidewalk or sidewalk apron to be constructed. Wood forms shall have a minimum thickness of 1 1/2 inches. Metal

forms shall be of a type approved by the Engineer and shall have flat top surface. The forms shall be cleaned, well oiled, securely staked, braced, and held to the required line and grade before any concrete is deposited. The forms shall be set at such elevations that the sidewalk will slope 1/4 inch per foot toward the roadway.

The concrete shall be deposited between the forms on the moistened subgrade, shall be struck off to a minimum four (4) inch thickness with six (6) inch thickness at driveways, and shall be worked sufficiently to bring the mortar to the surface. The surface shall then be made smooth and even by means of wooden floats and given a broom finish. All edges shall be rounded with an edging tool to four (4)-inch radius. The surface shall be divided into rectangular areas by means of a jointer having a radius of four (4) inches and forming a groove not less than one (1) inch in depth for the full width of the walk. The length of the rectangles formed shall not exceed the width of the sidewalk being constructed, unless otherwise specified by the Engineer.

The Contractor shall install four (4) inch pre-molded expansion joints extending entirely through the sidewalk at intervals not to exceed 100 feet, unless the sidewalk is constructed integral with the curb; in which case the width of joints and spacing shall conform to that in the curb. One-half inch premolded expansion joint material shall be installed to the full depth of the sidewalk where the walk abuts any rigid structure or fixtures such as curbs, columns, castings, buildings, light standards, etc.

The sidewalk and sidewalk aprons shall be cured in the same manner as specified for concrete pavement.

After the concrete has set sufficiently, the Contractor shall remove the forms and shall backfill the space on each side of the walk. The earth shall be compacted and graded in a satisfactory manner.

**4.3 CURB AND GUTTER.** Curb and gutter shall be constructed according to drawing shown on Exhibit 4-1, "Curb and Gutter Details." All curb and gutter shall be Portland Cement Concrete and shall be placed independently of street pavement.

**4.3.1 Construction Methods.** Construction of curb and gutter by method of setting forms and placing concrete by hand, the concrete shall be Class "A". It shall have minimum 28-day compressive strength of 3500 psi, and shall have a minimum slump of two (2) inches and a maximum slump of four (4) inches. For fiber reinforced concrete a slump tolerance of plus one-inch shall be allowed. Air entrainment shall be required with content by volume of 5.5 percent minimum and seven (7) percent maximum.

Curb and gutter constructed with the use of a slipform paver may use 4000 psi, 28-day strength concrete. See Chapter 13 "Concrete Specifications Materials and Methods" for recommended mix design.

**4.3.2 Subgrade.** The moistened subgrade upon which the curb and gutter is founded shall be accurately constructed to line; and grade and shall be compacted to the same density requirements as established hereinbefore for street subgrade. See "Curb and Gutter Details", Exhibit 4-1.

In the event curb and gutter is constructed prior to establishment of the street subgrade, the curb and gutter subgrade may be compacted by use of mechanical hand tamper or other methods approved by the Engineer. The width of the subgrade shall be not less than the width of the curb and gutter plus six (6) inches beyond each side of the curb and gutter.

Curb and gutter concrete shall not be placed until the subgrade has been inspected and approved by the Engineer.

**4.3.3 Forms.** The side forms for the construction of curbing and gutters shall be of wood or metal, shall be straight, free from warp and of sufficient strength when staked to resist the pressure of concrete without springing; and shall be rigidly set and staked to remain true to line and grade during the placing of the concrete.

The surface of the curb and gutter shall be accurately screeded from template to template on 8-ft. centers. Steel templates conforming to the shape of the curb and gutter as shown on approved plans shall be used.

When indicated on the plans or directed by the Engineer entrance and drainage openings of the required dimensions shall be formed through the curbing at the designated location.

The back of curb and gutter may be rolled down as approved by the Engineer to provide vehicle entrance and exit to private property per the Access Management Manual, Zoning Ordinance, and Subdivision Regulations.

After placing concrete, forms shall be removed in no less than six (6) hours or more than 24 hours.

**4.3.4 Concrete Placement.** After the subgrade has been prepared, it should be moistened before the concrete is placed. During placement, the concrete shall be thoroughly spaded or worked until the mortar entirely covers the surface and all honeycomb and voids are eliminated. The concrete shall be placed in such a manner that no concrete will have reached its initial set before the following layer is placed. The surfaces shall be struck off and floated so that all coarse aggregate is well below the surface.

Where required, reinforcing steel shall be placed in accordance with the details shown on plans.

Where concrete is placed by hand, steel guide templates spaced at 10-foot intervals shall be used. Where placed by a slip-form paving machine, tooled or sawed joints shall be spaced at 10-foot intervals.

**4.3.5 Concrete Finishing.** The top surfaces of the gutters shall be given a uniform float finish and the edges shall be rounded with an edging tool having a radius of three-eighths (3/8) inch.

The top surfaces of the curbs shall be given a uniform float finish and the edges shall be rounded to the radius shown on the plans. All honeycombed areas shall be corrected by filling with mortar, composed of 1:2 mixture by volume of cement and sand. Plastering will not be permitted. The top and face of all curbing shall be finished while the concrete is still green by wetting and rubbing with a soft brick or wooden block. The face of header curbs shall be finished to two (2) inches below the gutter line or the finished ground line. The concrete shall be finished to a smooth surface, presenting a uniform texture and color and be given a final broom finish.

**4.3.6 Protection and Curing.** Concrete shall be cured and protected as hereinbefore outlined in Chapter 13 “Concrete Specifications Materials and Methods.”

**4.4 RAMPS FOR HANDICAPPED.** Ramps for handicapped shall be included in curb and gutter and sidewalk construction as provided by Kentucky State Law as per KRS 66.660.

In order to enable persons using wheelchairs to travel freely and without assistance, at each crosswalk a ramp with nonslip surface shall be built into the curb so that the sidewalk and street blend to a common level. Such a ramp shall not be less than 48 inches wide (36 inches minimum) and shall not have a slope greater than one inch per 12 inches in length. In all ramps there shall be a gradual rounding at the bottom of the slope. For general construction guidelines, see Exhibits 4-2 and 4-3, “Handicap Ramp Details.”

ROLL CURB  
& GUTTER

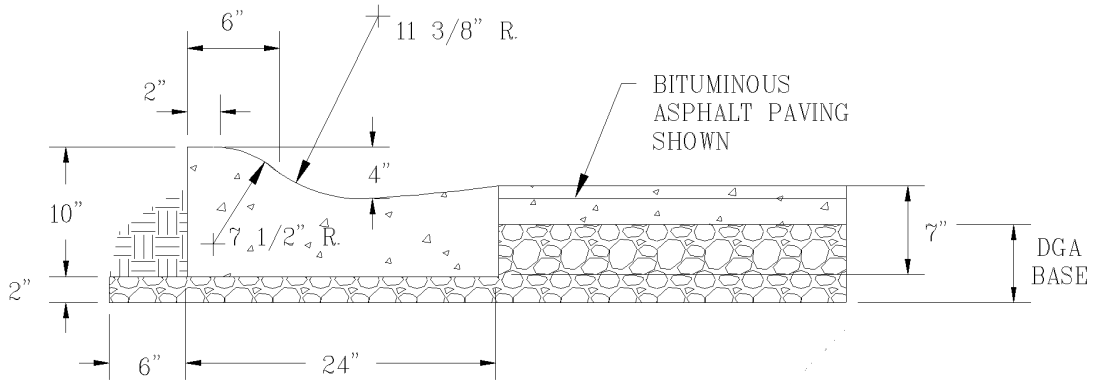

BOX CURB  
& GUTTER

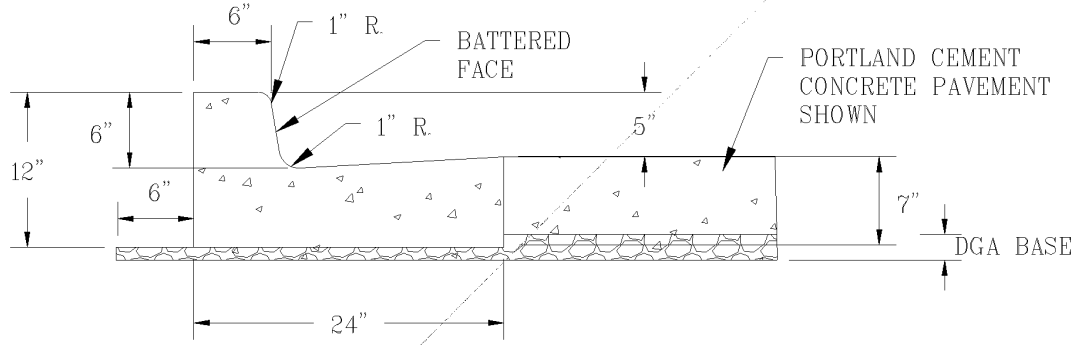

VALLEY CURB  
& GUTTER

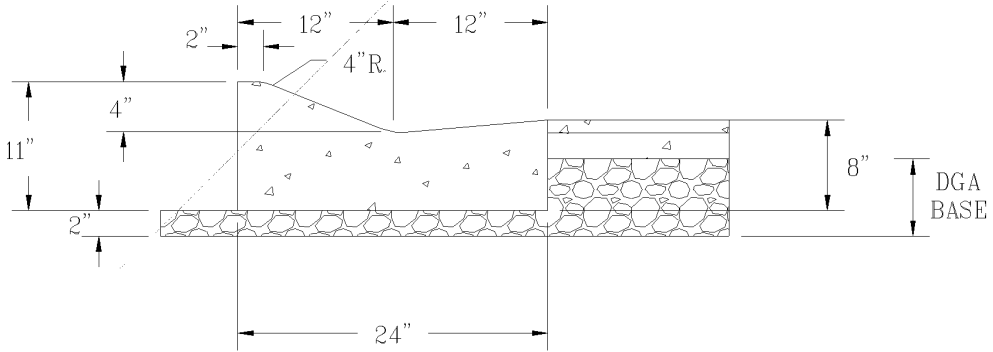

ROLL CURB  
AT DRIVEWAY

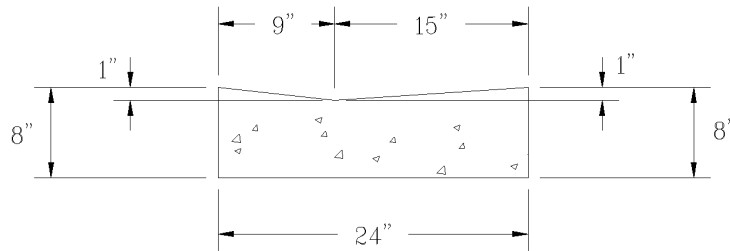

BOX CURB  
AT DRIVEWAY

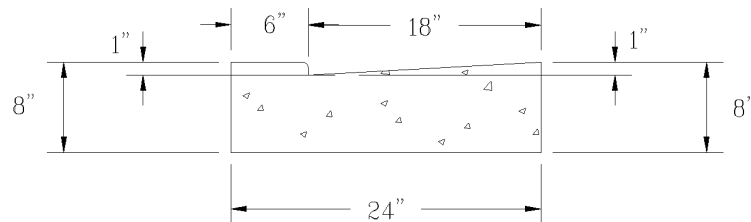

OWENSBORO METROPOLITAN  
PUBLIC IMPROVEMENT SPECIFICATIONS

CHAPTER 4  
SIDEWALKS, CURB, AND GUTTER

CURB AND GUTTER  
DETAILS

EXHIBIT 4-1  
NOT TO SCALE



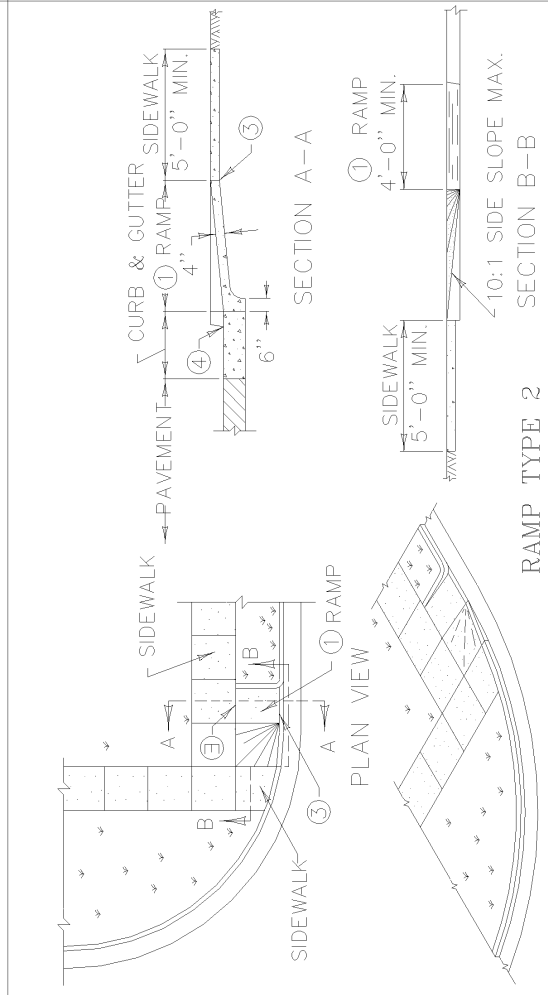
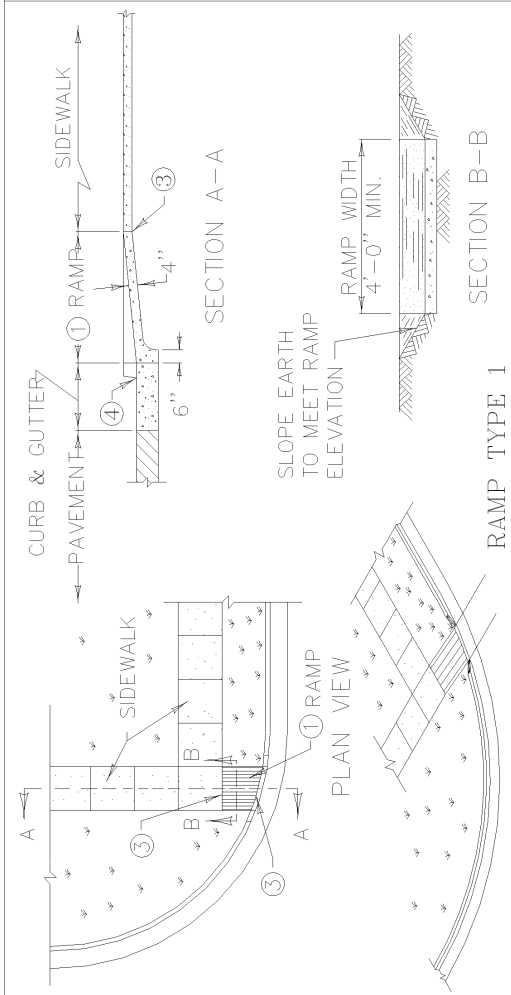

**NOTES**

- 1 RAMP SHALL BE PAID PER SQ. YARD OF 4" CONC. SIDEWALK AND THE UNIT PRICE SHALL INCLUDE ALL MATERIALS, FORMS, AND INCIDENTALS NECESSARY FOR CONSTRUCTION. THE RAMP SHALL BE CONSTRUCTED OF CLASS "A" CONCRETE. A BROOM FINISH OR EQUAL NON-SKID FINISH IS REQUIRED.
- 2 THE NORMAL GUTTER LINE SHALL BE MAINTAINED THROUGH THE AREA OF THE RAMP.
- 3 RAMP SHOULD BE LOCATED WITHIN MARKED LIMITS OF CROSSWALKS.
- 4 USE RAMP TYPE 3 WHEN POINT A TO B IS LESS THAN 20 FEET.
- 5 USE RAMP TYPE 4 WHEN POINT A TO B IS 20 FEET OR MORE.
- 6 MAX. RAMP SLOPE 12:1.
- 7 CURB RETURN REQUIRED WHEN UTILITY STRIP IS 4 FEET OR GREATER. FOR UTILITY STRIPS LESS THAN 4 FEET, THE AREA IS TO BE SURFACED WITH SIDEWALK WITHIN THE RAMP.
- 8 1/2" EXPANSION JOINT AT BACK OF CURB LINE AND AT SIDEWALK LINE.
- 9 NO BUMP PERMITTED. SAME SLOPE AS RAMP AND NOT TO EXCEED 1" IN HEIGHT.

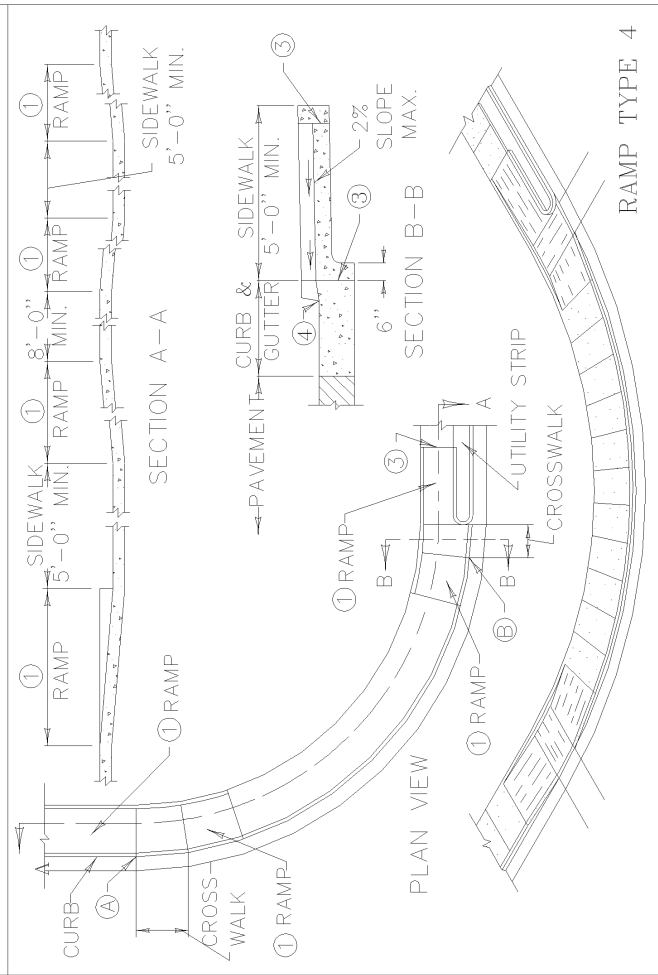
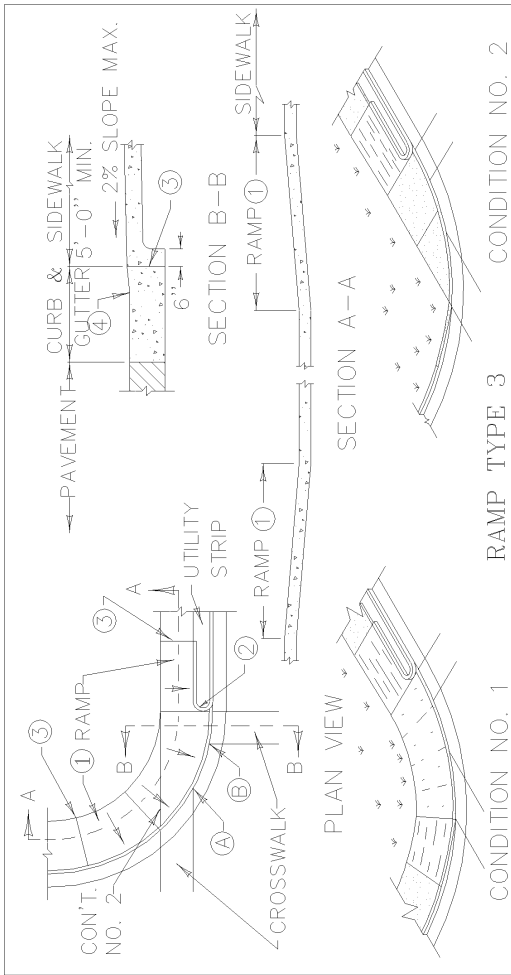

|   |  |
|---|--|
| OWENSBORO METROPOLITAN<br>PUBLIC IMPROVEMENT SPECIFICATIONS | CHAPTER 4<br>SIDEWALKS, CURB, AND GUTTER |
| HANDICAP RAMP<br>DETAILS                                    | EXHIBIT 4-3<br>NOT TO SCALE              |

